

NED B12Z

Section A-A

Section B-B

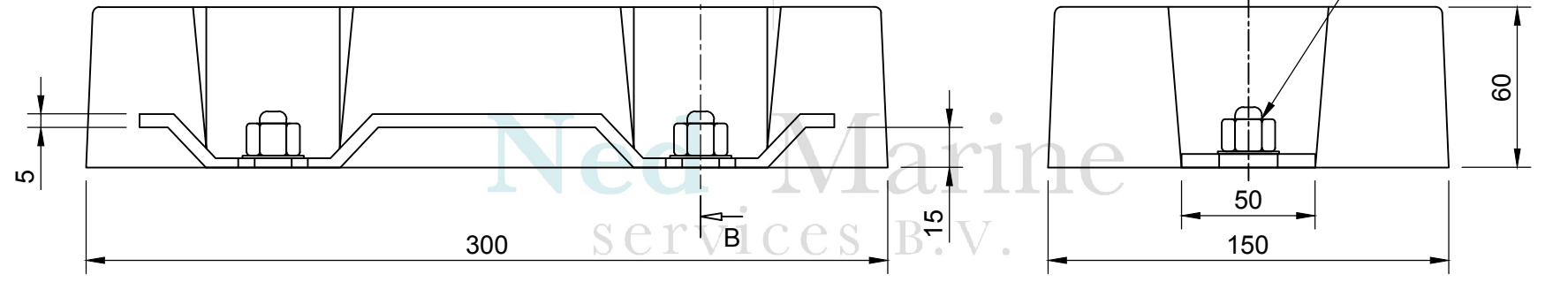

ZINC US-MIL-A-18001k ALLOY SPECIFICATION

Components:
 Al 0,1-0,5% range
 Fe 0,005% max
 Pb 0,006% max
 Cd 0,025-0,07% Max
 Cu 0,005% max
 Zn remaining

Capacity: 780 Ah/kg
 Efficiency: 95%
 Potential: - 1110 mV Cu -
 CuSO₄ electrolyte artificial sea water DIN 50905
 Insert quality: Plate, bar section EN10025 Grade S235/S275
 Insert welding: All fabrication of steel inserts are according EN10287 and EN10288

NET WEIGHT: 15,9 kg
 GROSS WEIGHT: 16,2 kg

Company address:
 Tinstraat 109
 2984AN Ridderkerk
 The Netherlands
 Tel. +31 (0) 180 420 055
 Fax. +31 (0) 180 499 810
 E-mail. info@nedmarine.com
 www.nedmarine.com



Drawing name: NED B12Z			
Drawing No.: 17.0155		Rev: \triangle 0	Sheet: 1/1
Drawn: R.D.	Approved: G.M.	Scale: -	Date: 19/09/2017

Ned T.D. 16 003